

wilkinsonstar.com



MIG Series

MIG/MAG/MMA Compact welding machines
Order code JM-350C (MIG 350C)



OPERATOR MANUAL

Your new product

Thank you for selecting this Jasic Technology, Wilkinson Star product.

This product manual has been designed to ensure that you get the most from your new product. Please ensure that you are fully conversant with the information provided paying particular attention to the safety precautions. The information will help protect yourself and others against the potential hazards that you may come across.

Please ensure that you carry out daily and periodic maintenance checks to ensure years of reliable and trouble free operation.

Wilkinson Star Limited are a leading supplier of equipment in the UK and our products are supported by our extensive service network. Call your distributor in the unlikely event of a problem occurring. Please record below the details from your product as these will be required for warranty purposes and to ensure you get the correct information should you require assistance or spare parts.

Date purchased _____

From where _____

Serial Number _____

(The serial number will normally be located on the equipment data plate on the underside of the machine or on the rear panel)

Please note products are subject to continual development and may be subject to change without notice

1

Safety Precautions



These general safety norms cover both arc welding machines and plasma cutting machines unless otherwise noted.

The equipment must only be used for the purpose it was designed for. Using it in any other way could result in damage or injury and in breach of the safety rules.

Only suitably trained and competent persons should use the equipment. Operators should respect the safety of other persons.



Prevention against electric shock

The equipment should be installed by a qualified person and in accordance with current standards in operation. It is the users responsibility to ensure that the equipment is connected to a suitable power supply. Consult with your utility supplier if required

If earth grounding of the work piece is required, ground it directly with a separate cable.

Do not use the equipment with the covers removed.

Do not touch live electrical parts or parts which are electrically charged.

Turn off all equipment when not in use.

Cables (both primary supply and welding) should be regularly checked for damage and overheating. Do not use worn, damaged, under sized, or poorly jointed cables.

Ensure that you wear the correct protective clothing, gloves, head and eye protection.

Insulate yourself from work and ground using dry insulating mats or covers big enough to prevent any physical contact with the work ground.

Never touch the electrode if you are in contact with the work ground, or another electrode from a different machine.

Do not wrap cables over your body.

Ensure that you take additional safety precautions when you are welding in electrically hazardous conditions such as damp environments, wearing wet clothing, and metal structures. Try to avoid welding in cramped or restricted positions.

Ensure that the equipment is well maintained. Repair or replace damaged or defective parts immediately. Carry out any regular maintenance in accordance with the manufacturers instructions.



Safety against fumes and welding gases

Locate the equipment in a well-ventilated position.

Keep your head out of the fumes. Do not breathe the fumes.

Ensure the welding zone is in a well-ventilated area. If this is not possible provision should be made for suitable fume extraction.

If ventilation is poor, wear an approved respirator.

Read and understand the Material Safety Data Sheets (MSDS's) and the manufacturer's instructions for metals, consumable, coatings, cleaners, and de-greasers.

Do not weld in locations near any de-greasing, cleaning, or spraying operations. Be aware that heat and rays of the arc can react with vapours to form highly toxic and irritating gases.

Do not weld on coated metals, unless the coating is removed from the weld area, the area is well ventilated, and while wearing an air-supplied respirator. The coatings on many metals can give off toxic fumes if welded.



Prevention against burns and radiation

Arc rays from the welding process produce intense, visible and invisible (ultraviolet and infrared) rays that can burn eyes and skin.

Wear an approved welding helmet fitted with a proper shade of filter lens to protect your face and eyes when welding or watching

Wear approved safety glasses with side shields under your helmet.

Never use broken or faulty welding helmets.

Always ensure there are adequate protective screens or barriers to protect others from flash, glare and sparks from the welding area. Ensure that there are adequate warnings that welding or cutting is taking place.

Wear suitable protective flame resistant clothing.

The sparks and spatter from welding, hot work pieces, and hot equipment can cause fires and burns

Welding on closed containers, such as tanks, drums, or pipes, can cause them to explode.

Accidental contact of electrode to metal objects can cause arcs, explosion, overheating, or fire.

Check and be sure the area is safe and clear of inflammable material before carrying out any welding.



Protection against noise

Some welding and cutting operations may produce noise.

Wear safety ear protection to protect your hearing.



Protection from moving parts

When the machine is in operation keep away from moving parts such as motors and fans. Moving parts, such as the fan, may cut fingers and hands and snag garments.

Protections and coverings may be removed for maintenance and controls only by qualified personnel, after first disconnecting the power supply cable.

Replace the coverings and protections and close all doors when the intervention is finished, and before starting the equipment.

Take care to avoid getting fingers trapped when loading and feeding wire during set up and operation.

When feeding wire be careful to avoid pointing it at other people or toward your body.

Always ensure machine covers and protective devices are in operation.



Precautions against fire and explosion

Avoid causing fires due to sparks and hot waste or molten metal

Ensure that appropriate fire safety devices are available near the cutting / welding area.

Remove all flammable and combustible materials from the cutting / welding zone and surrounding areas

Do not cut/weld fuel and lubricant containers, even if empty. These must be carefully cleaned before they can be cut/welded.

Always allow the cut/welded material to cool before touching it or placing it in contact with combustible or flammable material.

Do not work in atmospheres with high concentrations of combustible fumes, flammable gases and dust.

Always check the work area half an hour after cutting to make sure that no fires have begun.



Risks due to magnetic fields

The magnetic fields created by high currents may affect the operation of pacemakers or electronically controlled medical equipment.

Wearers of vital electronic equipment should consult their physician before beginning any arc welding, cutting, gouging or spot welding operations.

Do not go near welding equipment with any sensitive electronic equipment as the magnetic fields may cause damage.

RF Declaration

Equipment that complies with directive 2004/108/EC concerning electromagnetic compatibility (EMC) and the technical requirements of EN60974-10 is designed for use in industrial buildings and not those for domestic use where electricity is provided via the low voltage public distribution system. Difficulties may arise in assuring class A electromagnetic compatibility for systems installed in domestic locations due to conducted and radiated emissions.

In the case of electromagnetic problems, it is the responsibility of the user to resolve the situation. It may be necessary to shield the equipment and fit suitable filters on the mains supply.

LF Declaration

Consult the data plate on the equipment for the power supply requirements.

Due to the elevated absorbance of the primary current from the power supply network, high power systems affect the quality of power provided by the network. Consequently, connection restrictions or maximum impedance requirements permitted by the network at the public network connection point must be applied to these systems.

In this case the installer or the user is responsible for ensuring the equipment can be connected, consulting the electricity provider if necessary.



Materials and their disposal



The equipment is manufactured with materials, which do not contain any toxic or poisonous materials dangerous to the operator.

When the equipment is scrapped, it should be dismantled separating components according to the type of materials.

Do not dispose of the equipment with normal waste. The European Directive 2002/96/EC on Waste Electrical and Electronic Equipment states the electrical equipment that has reached its end of life must be collected separately and returned to an environmentally compatible recycling facility.



Handling of Compressed gas cylinders and regulators

All cylinders and pressure regulators used in welding operations should be handled with care.

Never allow the electrode, electrode holder or any other electrically "hot" parts to touch a cylinder.

Keep your head and face away from the cylinder valve outlet when opening the cylinder valve.

Always secure the cylinder safely

Never deface or alter any cylinder

2

Product Overview

The MIG 250 is an inverter power source that can provide MIG, MMA and gas less self- shielded welding welding options.

Its IGBT power device with unique control mode provides excellent reliability with a high duty cycle.

The system has a closed loop feedback control, constant voltage output, which allows it to operate with a wide tolerance to mains fluctuation, within $\pm 15\%$.

It has continuously adjustable welding voltage and current, to provide excellent welding characteristics.

Adopting a unique welding dynamic characteristic control circuit in MIG, provides a stable arc, low spatter, excellent weld appearance and high welding efficiency.

By removing the ball at the end of the wire after welding, a high no-load voltage, and slow wire feed at the start presents exceptional arc starting.

The machine also has a very stable welding current in MMA, excellent arc ignition, and can be used with a wide variety of welding electrodes.

Its high inverter frequency greatly reduces the volume and weight of the welder and the great reduction in magnetic and resistance loss obviously enhances the welding efficiency and energy saving effect.

Switching frequency is beyond audio range, which almost eliminates noise pollution.



3

Technical data

MODEL	MIG350C
Input power supply	3-phase 400V ± 15% 50HZ
Rated input capacity (KVA)	15
Rated output current (A)	350
Rated output voltage (V)	31.5
Rated duty cycle (%)	350A @ 40%
No-load voltage (V)	59 ± 2V
Output current range in MMA (A)	20 ~ 350
Output current range in MIG (A)	50 ~ 350
Output voltage range in MIG (V)	15 ~ 38
Electrode diameter applicable (mm)	0.8/0.9/1.0/1.2
Wire spool applicable (kg)	20
Wire feed speed range (m/min)	1.5 ~ 15
Wire feeder	4 roll
Insulation class	F
Cooling mode	Air-cooling
Protection class	IP21S
Power factor	0.93

Tested at the environment temperature of 40° C

Product design may vary due to customer requirements.

4 Controls

Front view

1. Euro connector of the welding torch in MIG
2. Current control knob in MMA
3. Voltage control knob in MIG
4. VRD LED
5. Power LED
6. Overheating LED
7. Wire inch button
8. Wire feed speed control knob in MIG
9. Voltage meter
10. Inductance control knob
11. Current meter
12. TIG/MMA/MIG switch
13. Push/Pull torch switch
14. Socket of wire pull torch control cable
15. “ + ” output terminal
16. Gas/gasless adapter
17. “ - ” output terminal

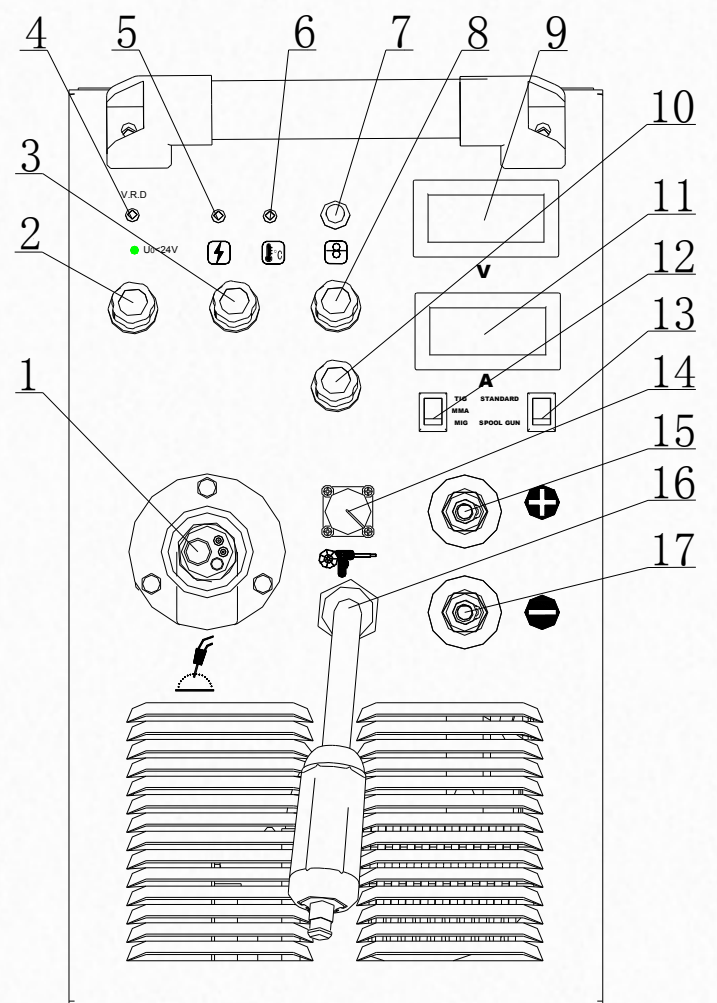

Rear View

18. Fan

19. Socket of gas regulator heater

20. Input power cord

21. Power switch

22. Grounding terminal

23. Gas inlet

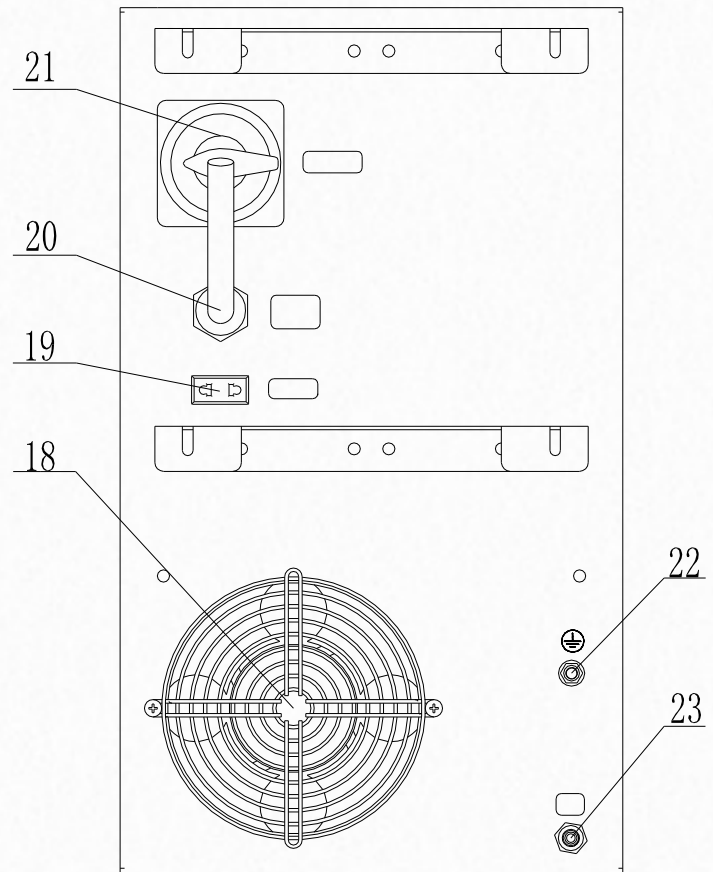

21. Burn back control

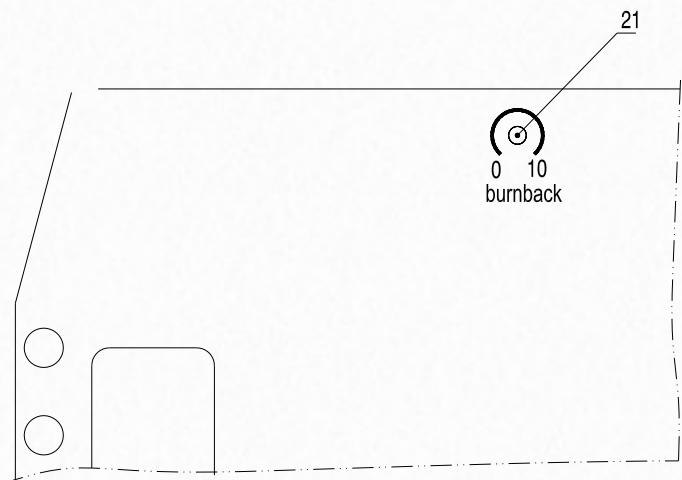

5

Installation

Unpacking

Check the packaging for any signs of damage.

Carefully remove the machine and retain the packaging until the installation is complete.

Location

The machine should be located in a suitable position and environment. Care should be taken to avoid moisture, dust, steam, oil or corrosive gases

Place on a secure level surface and ensure that there is adequate clearance around the machine to ensure natural airflow.

Input connection

Before connecting the machine you should ensure that the correct supply is available. Details of the machine requirements can be found on the data plate of the machine or in the technical parameters shown in the manual.

The equipment should be connected by a suitably qualified competent person. Always ensure the equipment has a proper grounding.

Never connect the machine to the mains supply with the panels removed.

Output connections

Electrode polarity

In general when using manual arc welding electrodes the electrode holder is connected to the positive terminal and the work return to the negative terminal. Always consult the electrode manufacturer's data sheet if you have any doubts.

When using the machine for TIG welding the TIG torch should be connected to the negative terminal and the work return to the positive terminal

MMA welding

Insert the cable plug with the electrode holder into the "+" socket on the front panel of the welding machine, and tighten it clockwise.

Insert the cable plug of the work return lead into the "-" socket on the front panel of the welding machine, and tighten it clockwise

TIG welding

Insert the cable plug with the TIG torch into the "-" socket on the front panel of the welding machine, and tighten it clockwise.

Connect the TIG torch gas hose to the gas regulator

Insert the cable plug of the work return lead into the "+" socket on the front panel of the welding machine, and tighten it clockwise

MIG Welding

Insert the welding torch into the "Euro connector for torch in MIG" output socket on the front panel of the machine, and tighten it.

Install the wire spool on the spindle adapter.

Connect the cylinder equipped with the gas regulator to the gas inlet on the back panel of the machine with a gas hose.

Insert the cable plug with work clamp into the "-" output terminal on the front panel of the welding machine, and tighten it clockwise.

Insert the quick plug of the gas / no gas selector into the "+" output terminal of the welding machine, and tighten it clockwise.

Ensuring that the groove size in the feeding position on the drive roll matches the contact tip size of the welding torch and the wire size being used. Release the pressure arm of

the wire feeder to thread the wire through the guide tube, and into the drive roll groove. Adjust the pressure arm, ensuring no sliding of the wire. Too high pressure will lead to wire distortion, which will affect wire feeding. Press the wire inch button to thread the wire out of the torch contact tip.

Gas less Self Shielded Welding

Insert the welding torch into the “Euro connector for torch in MIG” output socket on the front panel of the machine, and tighten it.

Insert the cable plug with work clamp into the “+” output terminal on the front panel of the welding machine, and tighten it clockwise.

Insert the quick plug of the gas / no gas selector into the “-” output terminal on the middle plate of the welding machine, and tighten it clockwise.

Install the wire spool on the spindle adapter, ensuring that the groove size in the feeding position on the drive roll matches the contact tip size of the welding torch and the wire size being used. Release the pressure arm of the wire feeder to thread the wire through the guide tube, and into the drive roll groove. Adjust the pressure arm, ensuring no sliding of the wire. Too high pressure will lead to wire distortion, which will affect wire feeding. Press the wire inch button to thread the wire out of the torch contact tip.

Operation

Before starting any welding activity ensure that you have suitable eye protection and protective clothing. Also take the necessary steps to protect any persons within the area.

MMA

After connecting the welding leads as detailed you will need to switch on the machine. The power LED will be lit and the fan running.

Switch the TIG/MMA/MIG switch to MMA.

Set the amperage on the machine using the MMA current control knob to a value suitable for the electrode being used. Please see below a guide to amperages required. Ensure you check that you have the electrode polarity correct.

Electrode Diameter (mm)	Recommended Welding Current (A)
1.0	20~60
1.6	44~84
2.0	60~100
2.5	80~120
3.2	108~148
4.0	140~180
5.0	180~220
6.0	220~260

TIG

After connecting the welding leads as detailed you will need to switch on the machine. The power LED will be lit and the fan running.

Switch the TIG/MMA/MIG switch to TIG.

Set the amperage on the machine using the MMA current control knob to a value suitable for the electrode being used.

Open the gas valve on the TIG torch and set the required flow rate

Start the arc by touching the TIG electrode to the work piece and raising it.

MIG/MAG

Connect the MIG torch leads as detailed above. Ensure that a suitable inert gas supply is connected.

Switch the power switch on the back panel to "ON", the machine is started with the power LED on and the fan working.

Switch the MMA/MIG switch to MIG mode.

Select pull position if using a remote torch

Open the gas valve of the cylinder, and adjust the gas regulator to obtain the desired flow rate.

Adjust the "voltage control knob in MIG" and "wire feed speed control knob in MIG" on the front panel of the machine to get the correct welding voltage and welding current.

Operate the torch trigger, and welding can be carried out.

Where required adjust the burn-back time potentiometer (above the feed unit inside the machine) to get the proper electrode stick-out.

One second after the arc stops, the gas supply will be cut off.

Gas less MIG

The operation method is the same to MIG operation except that there are no gas options.

For welder training please visit our Academy website at

www.wilkinson-welding-academy.com

6

Maintenance and troubleshooting

The following operation requires sufficient professional knowledge on electric aspects and comprehensive safety knowledge. Make sure the input cable of the machine is disconnected from the electricity supply and wait for 5 minutes before removing the machine covers.

In order to guarantee that the arc welding machine works efficiently and in safety, it must be maintained regularly. Operators should understand the maintenance methods and means of arc welding machine operation. This guide should enable customers to carry on simple examination and safeguarding by oneself, try to reduce the fault rate and repair times of the arc welding machine, so as to lengthen service life of arc welding machine

Period	Maintenance item
Daily examination	Carry out a full visual inspection. Check for any damage to the machine, leads, cables and connections. Replace where necessary. Switch on the machine and check for any warning Led's and general operation
Monthly examination	Using the dry compressed air to clean the inside of arc welding machine. Especially check for build up of dust / debris on intake grills, main voltage transformer, inductance, IGBT module, the fast recover diode and PCB, etc. Take care when blowing electronic components and do not dislodge any wiring connections Check the security of output connections and plugs. Replace if signs of overheating.
Yearly examination	Carry out an annual service. Check earth continuity and insulation resistance of the machine at the relevant points. PLEASE NOTE THIS WORK SHOULD BE CARRIED OUT BY A TRAINED COMPETENT PERSON.

Troubleshooting

Before arc welding machines are dispatched from the factory, they have already been checked thoroughly. The machine should not be tampered with or altered.

Maintenance must be carried out carefully. If any wire becomes loose or is misplaced, it maybe potential danger to user!

Only professional maintenance personnel should repair the machine!

- 1) Check if the switches on the front panel are in correct position.
- 2) Check if the 3-phase power is 340~420V, and if phase failure occurs.
- 3) Check if the input cable of the machine is correctly and well connected.
- 4) Check if the machine is correctly and reliably earthed.
- 5) Check if the welding cable is correctly and well connected.
- 6) Check if the gas path and gas regulator is in good condition.

Note: The voltage inside the machine can reach up to 600V, so do not uncover the machine due to safety hazard. Ensure the power is disconnected before working on the machine. Always wait 5 minutes after power switch off before opening the case.

Take necessary protection during troubleshooting and maintenance work to avoid electric shock. Cut off the power before the installation of welding cable and replacement of torch parts.

Symptom	Possible solution
The overheating LED is on.	<ol style="list-style-type: none"> 1. Check the welding current and welding time. Refer to the manual, and operate according to the duty cycle requirement. 2. Check the running status of the fan when welding. If the fan does not work, check if the power supply of the fan is 220V: If the power supply is normal, check the fan; if the power supply is abnormal, check the connecting cable of the power supply. 3. Replace the thermal switch if it is damaged.
The power LED is off, and there is no output current.	<ol style="list-style-type: none"> 1. Check if the fan works. If it does not work, it indicates that the power cord is not in good contact. 2. If the fan works, it indicates that the control PCB PK-131 inside the machine fails.
There is no response when pushing the torch trigger, and the protection LED is off.	<ol style="list-style-type: none"> 1. Check if the gun trigger is in good contact. 2. Check if the welding torch is well connected to the European connector, and check the control jack of the European connector. 3. The wire feed PCB PH-119 inside the machine fails.
When torch trigger is pressed, wire feeder works and gas comes out, but there is no output current, and the protection LED is off.	<ol style="list-style-type: none"> 1. Check if the cable to the workpiece is in good contact. 2. Check if the quick plug is connected to correct quick socket. 3. Check the welding torch for damage. 4. The control PCB PK-131 inside the machine fails.
There is output current when pushing the torch trigger to feed gas, but the wire feeder does not feed wire.	<ol style="list-style-type: none"> 1. Check the wire feeder for clogging or damage. 2. Check the contact tip of welding torch for clogging or damage. 3. The wire feed PCB PH-119 inside the machine fails.
Welding can be carried out when pushing the torch trigger, but the voltage cannot be adjusted.	<ol style="list-style-type: none"> 1. Check if the voltage feedback wire inside the machine is in good condition. 2. The control PCB PK-131 inside the machine fails.
Welding current is unstable.	<ol style="list-style-type: none"> 1. Check the pressure arm on the wire feeder for proper pressure. 2. Check if the drive roll matches the wire size being used. 3. Check the contact tip of the welding torch for wear. Replace it and tighten it if necessary. 4. Check the welding wire for good quality. 5. Check if the torch cable is too twisted. 6. Check if the quick plug is loose.

Symptom	Possible solution
Weld bead is not well protected.	<ol style="list-style-type: none"> 1. Do not move the welding torch away immediately when stopping welding, so that the shielded gas can protect the weld bead. 2. Prolong the post-flow time of the shielded gas.
No gas flow when the torch trigger is pushed, but the wire feed operates normally.	<ol style="list-style-type: none"> 1. The control PCB is damaged. 2. The solenoid valve is clogged or damaged. 3. The transformer of the power supply is damaged.

7

Electrical schematic

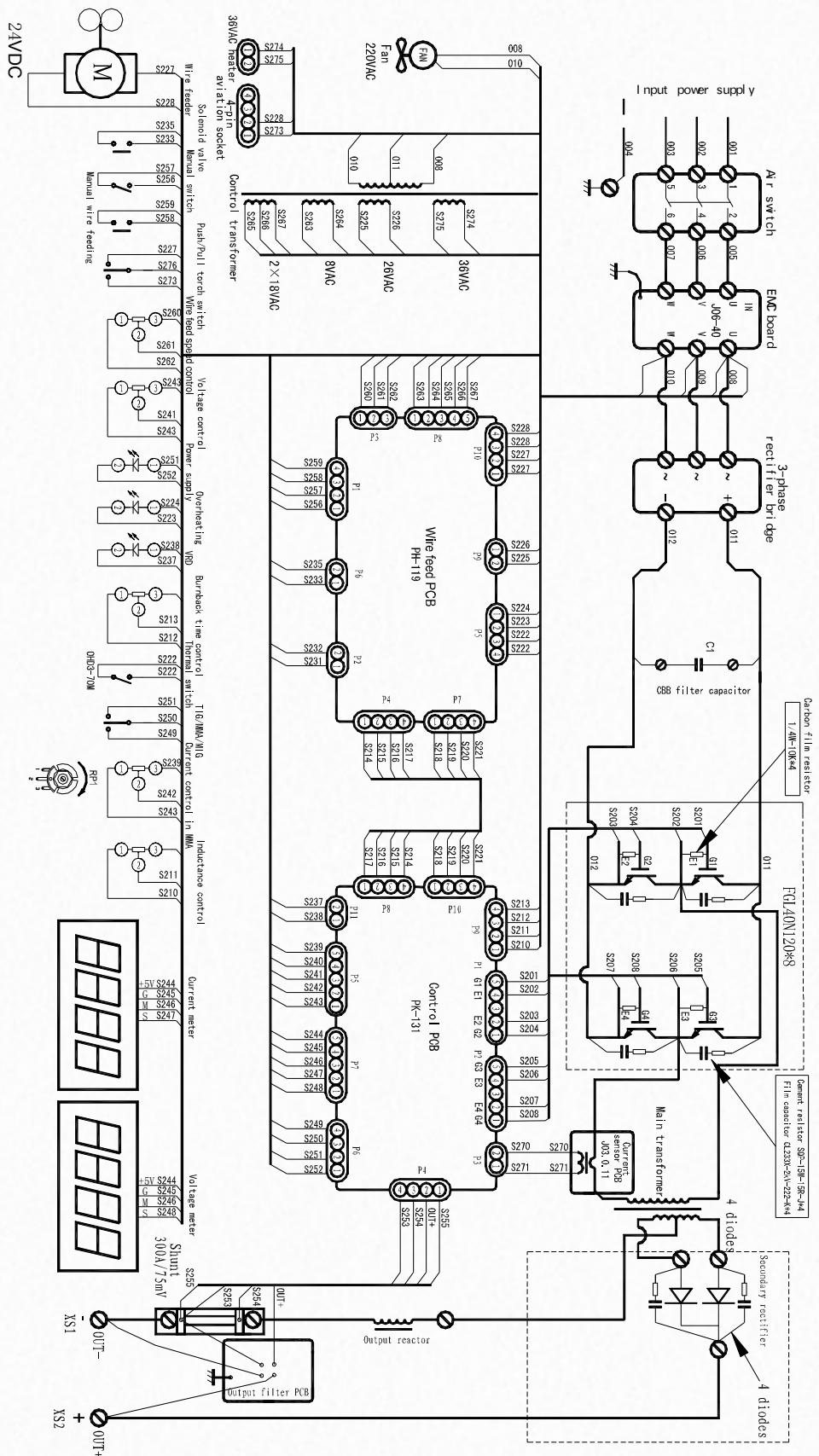

8

Parts list

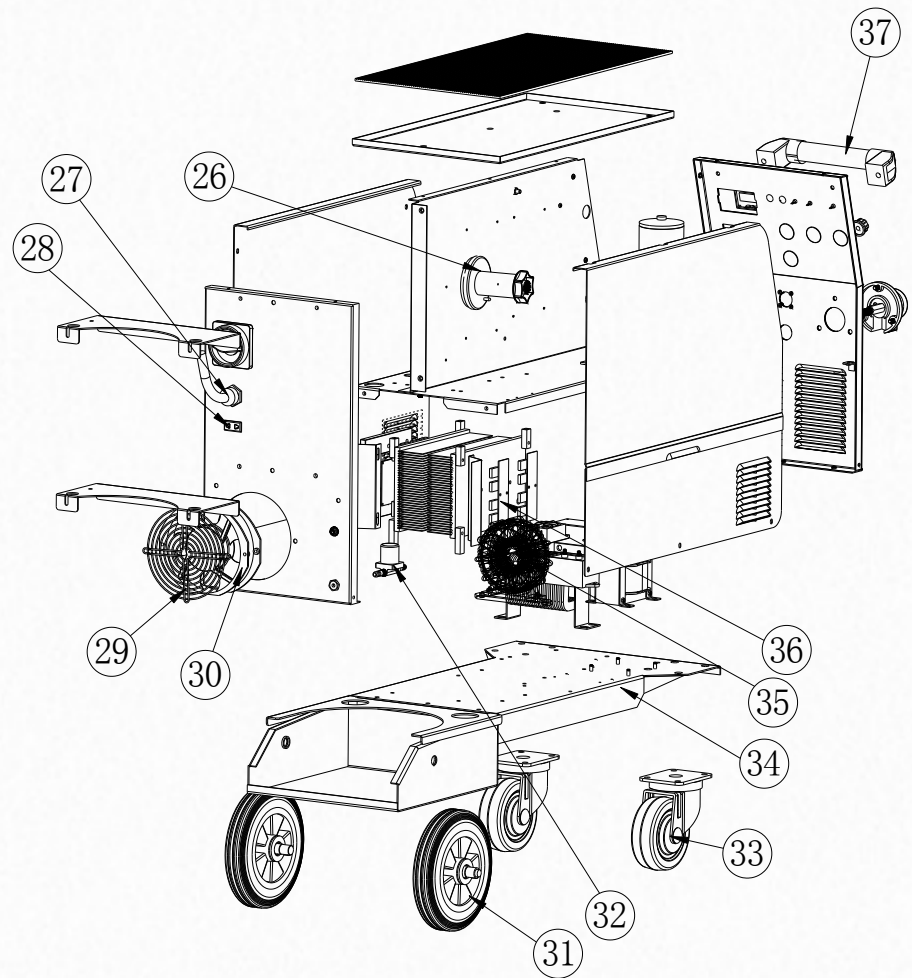
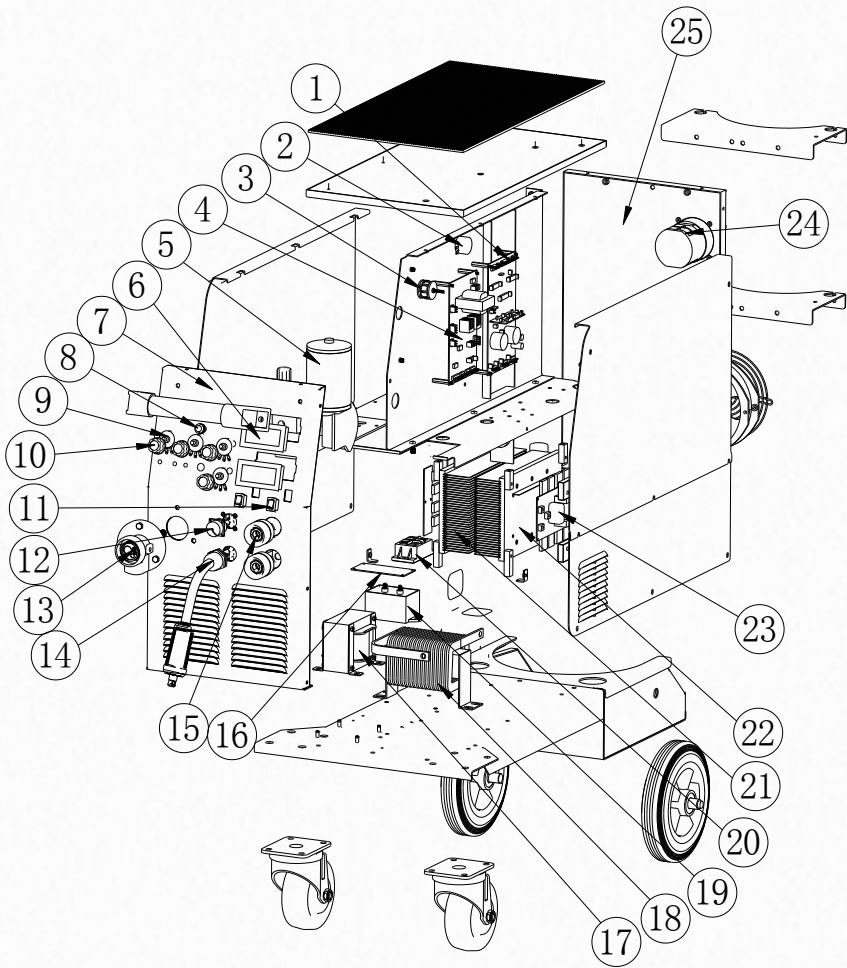

No.	Part no	Description	No.	Part no	Description
1	10000648	Control Board	19	10005913	Non inductive capacitor
2	10006508	Burn back potentiometer	20	10006635	Three - phase rectifier bridge
3	10005001	Choke	21	10016296	Rectifier heatsink
4	10000891	Wire feed PCB	22	10016295	Inverter heatsink
5	10003813	Wire feeder	23	10001960	Inverter board
6	10006797	Digital Meter	24	10004935	Mains switch
7	10015103	Front Panel	25	10047789	Back Panel
8	10003585	Inching switch	26	10016685	Hub assembly
9	10006505	Speed potentiometer	27	10001429	Power cable
	10006506	Current / voltage potentiometer	28	10004744	Square sockets
10	10004918	Knob	29	10007332	Fan network
11	10004942	Standard / Spool gun switch	30	10001856	Fan
12	10004695	Socket	31	10016535	Wheel
13	10004703	Euro connector	32	10001356	Solenoid valve
14	10003348	Polarity lead	33	10016534	Swivel wheel
15	10004639	Quick Socket	34	10039181	Bottom Panel
16	10000849	Power adapter plate	35	10006182	Main transformer
17	10001053	Power transformer	36	10000332	Rectifier plate
18	10002014	Reactor	37	10016698	Handle

JM MIG Series MIG/MAG/MMA WELDING MACHINE
Order code JM-350C (MIG 350)

© Wilkinson Star Limited

Issue 1 January 2014

Product is subject to change without notice